



Defender™ 3000 Series

Economy line of Indicators, Bases and Bench Scales



Designed with affordability in mind, but with no compromise on quality!

The OHAUS Defender™ 3000 Series economy line of dry or wet-use indicators, bases and bench scales is ideal for general weighing and simple counting applications in production, packaging, warehouse, inventory, shipping and receiving areas. Used in both bench and floor scale configurations, they feature a simple yet rugged tubular-frame base design and indicators with positive feedback keys, high-contrast backlit LCD display, built-in rechargeable battery operation and flexible mounting capabilities. The OHAUS Defender 3000 Series is the solution to your weighing applications that require dependability within an affordable budget.

Standard Features Include:

- Two rugged indicator models:
 - T31P indicator features a high-impact ABS housing that is reversible for either wall, column or table-top mounting
 - T32XW indicator features a 304 stainless steel housing with IP65 dust-tight and washdown protection; it features a flip-down front cover and only 4 sealing screws for ease of servicing
- Two base versions in three sizes:
 - 304 stainless steel pan with painted carbon steel frame and aluminum IP67 load cell
 - 304 stainless steel pan, frame and IP67 load cell
- Four scale capacity models: 30kg, 60kg, 150kg, 300kg
- Scales with maximum displayed resolutions 1:6000-7500d, Type-approved 1:3000e
- Built-in RS232 bidirectional interface, for printing and data communications
- Internal rechargeable sealed lead-acid battery included

Defender™ 3000 Indicators, Bases and

Indicator Specifications

Models:	T31P	T32XW
Construction	ABS plastic with internal reinforcing ribs Reversible front-rear cover with 4 key-hole mounts in rear housing	304 stainless steel NEMA 4X / IP65 PCB enclosure 304 stainless steel wall mount bracket with adjustment knobs
Housing Dimensions (W x D x H)	210 x 71 x 168 mm	212 x 71 x 149 mm
Full Scale Capacity Range	5 to 20,000 kg / lb	
Max Displayed / Approval Resolution	1:20,000d / 1:6000e	
Weighing Units	kg, lb, g, oz, lb:oz	
Extra Functions/Modes	Parts Counting	
Minimum Average Piece Weight	1d	
Sample Size	5, 10, 20, 50, 100, 200 (user selectable)	
Weight Display	25mm/1" High, 6-digit, 7-segment LCD with high-contrast white LED backlight	
Keyboard	4 function mechanical switches, raised, tactile	4 function membrane switches, raised, tactile
Load Cell Drive	up to 4 x 350 ohm Load Cells	
Load Cell Excitation Voltage	5V DC	
Load Cell Input Sensitivity	up to 3 mV/V (min 1 µV/d)	
Stabilization Time	within 2 seconds	
Auto-Zero Tracking	Off, 0.5, 1 or 3 divisions	
Key Zeroing Range	2% or 100% of capacity	
Span Calibration	5 kg/lb to 100% of capacity	
Interface	Bi-directional RS232C	
Power	9 VDC, 0.5A, AC adapter	100-240 VAC / 50/60 Hz universal power supply, hardwire cord
Battery	Internal rechargeable sealed lead acid battery, 100-hour typical operation with full charge	Internal rechargeable sealed lead acid battery, 58-hour typical operation with full charge
Operating Temperature Range	-10°C to 40°C	
Humidity Range	80% for temperatures up to 31°C, decreasing linearly to 50% at 40°C, non-condensing	
Net Weight	1.6kg	3.2kg
Shipping Weight	2.6kg	4.4kg
Shipping Dimensions (W x D x H)	272 x 235 x 175 mm	271 x 234 x 182 mm
Other Features	Environmental filtering, geographical gravity adjustment	

Outline Dimensions, Indicators

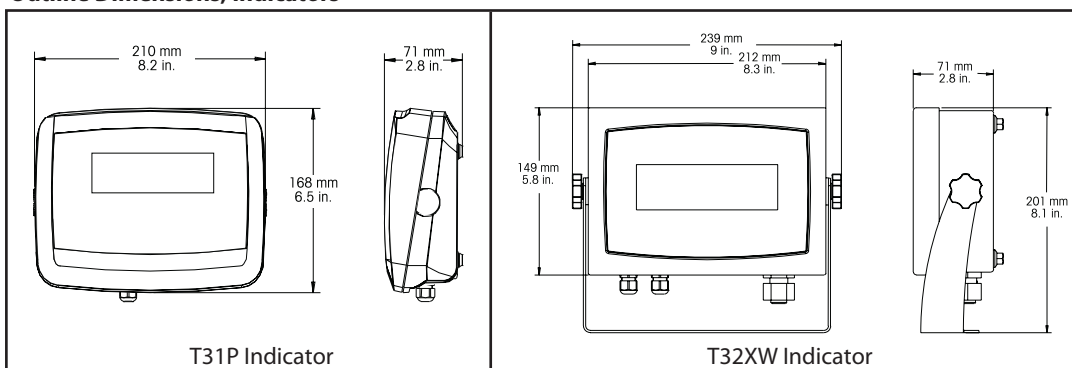

T31P Indicator shown with optional wall mount bracket



T32XW Indicator shown with included wall mount bracket

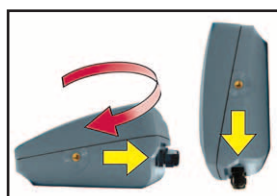

Reversible cover for cable exit above or below the housing, T31P



Structural ribs minimize flexing and gives strength to the housing, T31P



Integrated key-hole mounts for wall mounting without brackets, T31P

Base Specifications

Base Models:	D30BR	D60BR	D60BL	D150BL	D150BX	D300BX
Construction	304 stainless steel pan, painted carbon steel tubular frame, non-slip rubber leveling feet					
Net Weight	9 kg		16 kg		28 kg	
Shipping Weight	11 kg		19 kg		32 kg	
Load Cell Protection/Class	IP67, aluminum, single point / C3					
Base Models:	D30VR	D60VR	D60VL	D150VL	D150VX	D300VX
Construction	304 stainless steel pan and frame, non-slip rubber leveling feet					
Net Weight	9 kg		18 kg		33 kg	
Shipping Weight	11 kg		21 kg		37 kg	
Load Cell Protection/Class	IP67, stainless steel, single point / C3					
Capacity (max) x Readability (d)	30 kg x 5 g	60 kg x 10 g	60 kg x 10 g	150 kg x 20 g	150 kg x 20 g	300 kg x 50 g
Maximum Resolution	1:6000			1:7500		1:6000
Capacity (max) x Approvable Readability (e)	30 kg x 10 g	60 kg x 20 g	60 kg x 20 g	150 kg x 50 g	150 kg x 50 g	300 kg x 100 g
Approval Resolution (n max)	1:3000					
Load Cell Capacity	50 kg	100 kg		300 kg		500 kg
Load Cell Cable	2m L x 6-wire			2.3m L x 6-wire		
Load Cell Rated Output	2 mV/V ± 10%					
Load Cell Excitation Voltage	Maximum 20V (AC/DC) / Recommended 5~15V (AC/DC)					
Load Cell Input / Output Resistance	410 ± 10 ohms / 350 ± 4 ohms					
Leveling Components	Externally visible level bubble and adjustable leveling feet					
Operating Temperature	-10°C to 40°C					
Safe Overload Capacity	125% of rated scale capacity					
Base Dimensions (A x B x C x D x E)	355 x 305 x 123 x 75 x 380 mm		550 x 420 x 136 x 80 x 575 mm		650 x 500 x 143 x 90 x 675 mm	
Shipping Dimensions (W x D x H)	642 x 497 x 212 mm		857 x 564 x 225 mm		1,022 x 687 x 247 mm	

Options and Accessories

Ohaus Number

Wall mount bracket kit (includes adjustment knobs), T31P, painted carbon steel.....	80251747
Wall mount bracket kit (includes adjustment knobs), T32XW, stainless steel.....	80251748
Column Kits, painted steel: fixed height.....	80251743 (35cm) / 80251744 (70cm)
Column Kits, stainless steel: fixed height.....	80251745 (35cm) / 80251746 (70cm)

Approvals

- **Safety and EMC:** EN60950, EN61326, FCC, CE.
- **Type Approval/Legal-for-Trade:**
 - T31xx/T32XW Series Indicator: EC Type approval and Test Certificate: TC7085 / T5980
 - Base/Load Cell: OIML R60/2000-NL1-03.10 / TC5382; OIML R60/2000-NL1-03.14 / TC5367
- **Quality:** Ohaus quality management system registered to ISO 9001:2008

Outline Dimensions, Bases

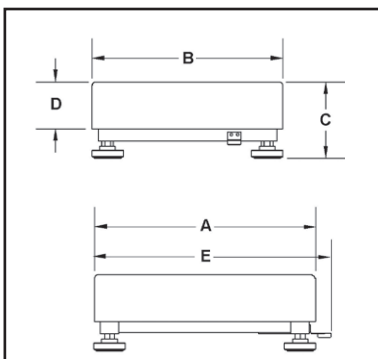

Three base sizes

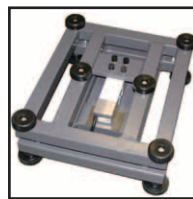

Painted steel version
'R' size

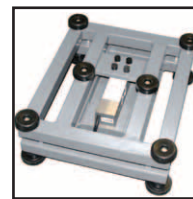

Stainless steel version
'R' size

Angular tubular frame design without compromise on durability

Defender™ 3000 Bench Scales

Scale Specifications

Models:*	D31P30BR	D31P60BR	D31P60BL	D31P150BL	D31P150BX	D31P300BX
Indicator Unit	T31P (wall mount bracket included with scale)					
Base Unit	D30BR	D60BR	D60BL	D150BL	D150BX	D300BX
Column	350 mm fixed height, painted steel			700 mm fixed height, painted steel		
Net Weight	12 kg		19 kg		32 kg	
Shipping Weight	15 kg		23 kg		37 kg / 82	
Scale Models:*	D32XW30BR	D32XW60BR	D32XW60BL	D32XW150BL	D32XW150BX	D32XW300BX
Indicator Unit	T32XW					
Base Unit	D30BR	D60BR	D60BL	D150BL	D150BX	D300BX
Column	350 mm fixed height, stainless steel			700 mm fixed height, stainless steel		
Net Weight	15 kg		23 kg		33 kg	
Shipping Weight	18 kg		26 kg		38 kg	
Scale Models:*	D32XW30VR	D32XW60VR	D32XW60VL	D32XW150VL	D32XW150VX	D32XW300VX
Indicator Unit	T32XW					
Base Unit	D30VR	D60VR	D60VL	D150VL	D150VX	D300VX
Column	350 mm fixed height, stainless steel			700 mm fixed height, stainless steel		
Net Weight	15 kg		24 kg		38 kg	
Shipping Weight	19 kg		28 kg		44 kg	
Capacity (max) x Enhanced Readability (d)	30kg x 5g	60kg x 10g	60kg x 10g	150kg x 20g	150kg x 50g	300kg x 50g
Max Displayed Resolution	1:6000			1:7500		1:6000
Capacity (max) x Approvable Readability (e)	30kg x 10g	60kg x 20g	60kg x 20g	150kg x 50g	150kg x 50g	300kg x 100g
Approval Resolution	1:3000	1:3000	1:3000	1:3000	1:3000	1:3000
Front View Dimensions (F1 x F2 x F3 x F4 x F5 x F6)	210 x 166 x 305 x 119 x 75 x 256 mm		210 x 166 x 420 x 145 x 80 x 371 mm		210 x 166 x 500 x 154 x 90 x 440 mm	
Side View Dimensions (S1 x S2 x S3 x S4 x S5)	572 x 472 x 355 x 306 x 52 mm		920 x 668 x 550 x 500 x 52 mm		920 x 740 x 650 x 590 x 52 mm	
Shipping Dimensions	642 x 497 x 212 mm		857 x 564 x 225 mm		1,022 x 687 x 247 mm	

*Notes: Not all models may be available in your area; check availability with your authorized Ohaus representative. Refer to component specifications for all other technical data. Column and wall mount bracket are supplied with scales.

Outline Dimensions, Scales

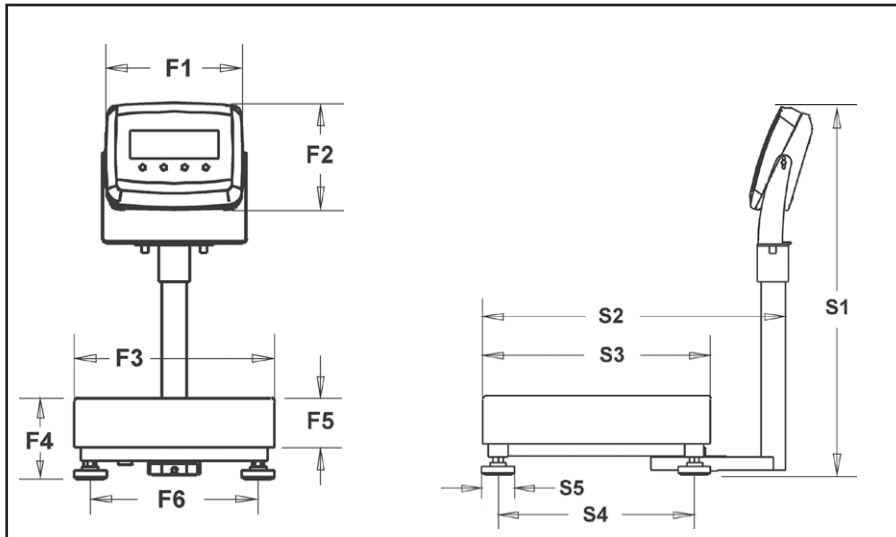

Proudly Sold & Serviced By:

Able Scale Co Pty Ltd

Ph: 1300 731 360

21 Green St Thomastown VIC. 3074

find us on the web: www.ablescale.com.au

www.ohaus.com

* ISO 9001:2008
Registered Quality Management System

80774267_E © Copyright Ohaus Corporation

